

**APPLICATION**

- ▶ For built-in furniture, kitchen cabinets, serving hatches, shop fixtures, etc.
- ▶ For two or three doors bi-passing, within the opening, on two parallel lines of track.
- ▶ For two doors bi-parting, clear of the opening, on one line of track.
- ▶ 'Slipper' requires only 13mm headroom.
- ▶ No bottom channel required in the threshold.
- ▶ Simple to remove the door for cleaning or decorating. The door merely hooks off the track once the guides have been unscrewed.

**DOOR SPECIFICATION**

**Track System:** Slipper 9

For Individual Doors:

Max Door Weight 9kg  
Max Door Width 1200mm  
Min Door Thickness 16mm

Lightly framed timber doors, flush doors or doors made from medium density fibreboard (MDF).

16mm thick MDF weighs 12.6kgm<sup>2</sup>.

For best operation, doors should be wider than the height.

**STANDARD SETS AND PACK**

Sets comprise two tracks, four sliders, three guides, one door stop, all screws and installation instructions for two doors.

Set No.	Opening width and track length	Door width for bi-passing doors	Hardware for
SS3	900mm	456mm	2 doors
SS4	1200mm	606mm	2 doors
SS5	1500mm	756mm	2 doors
SS6	1800mm	906mm	2 doors
SS8	2400mm	1206mm	2 doors

**Pack No.**

SS1 1 door pack comprises two sliders, three guides, one door stop and all screws for installing an additional door on an above set.

**HARDWARE SPECIFICATION**

**Track:** 130  
Material Aluminium  
Standard lengths 900mm, 1200mm, 1500mm, 1800mm, 2400mm and 3600mm

Countersunk for fitting direct to lintel

**Slider:** 131  
Material White nylon  
Sliders are moulded with radiused sides for ease of installation and for a smooth sliding action. Design enables door to be easily installed or removed.

**Guide:** 132  
Material White nylon  
Guides are fitted on the threshold of the cupboard. The guides can be positioned on both sides of the door or slide in a sawcut in the centre line of the door – see overleaf.

**Door Stop:** 28N  
Made from white nylon. Fit on the back of the front door to prevent finger being jammed in the finger pull on the back door.

**Accessories:**  
**Finger Pull:** 26  
Finger pull chrome plated brass. Push-fit into 32mm diameter by 10mm deep recess.

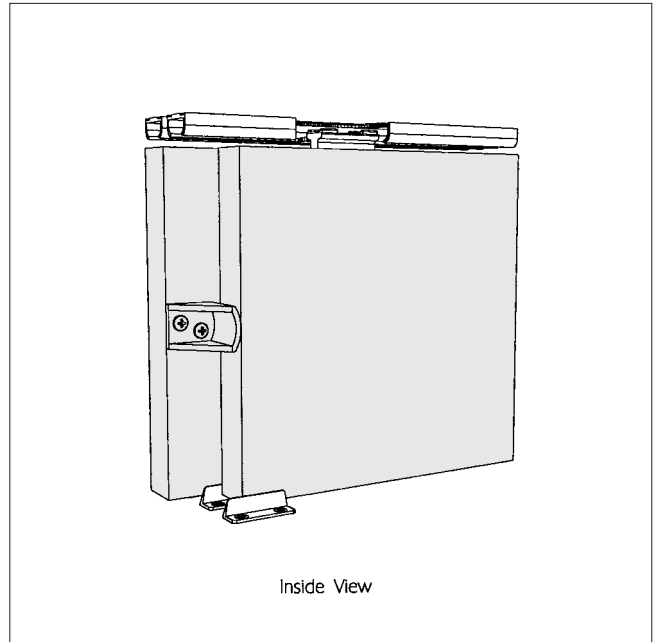

Inside View

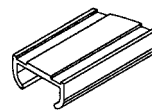

No. 130 Track

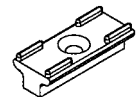

No. 131 Slider

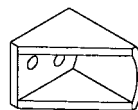

No. 28N Door Stop

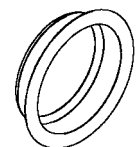

No. 26 Finger Pull

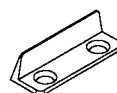

No. 132 Guide

# Slipper 9

FOR TOP HUNG SLIDING CUPBOARD DOORS, MAX. 9kg EACH

**HENDERSON**<sup>®</sup>  
SLIDING & FOLDING DOOR HARDWARE  
AUSTRALIA'S WIDEST RANGE

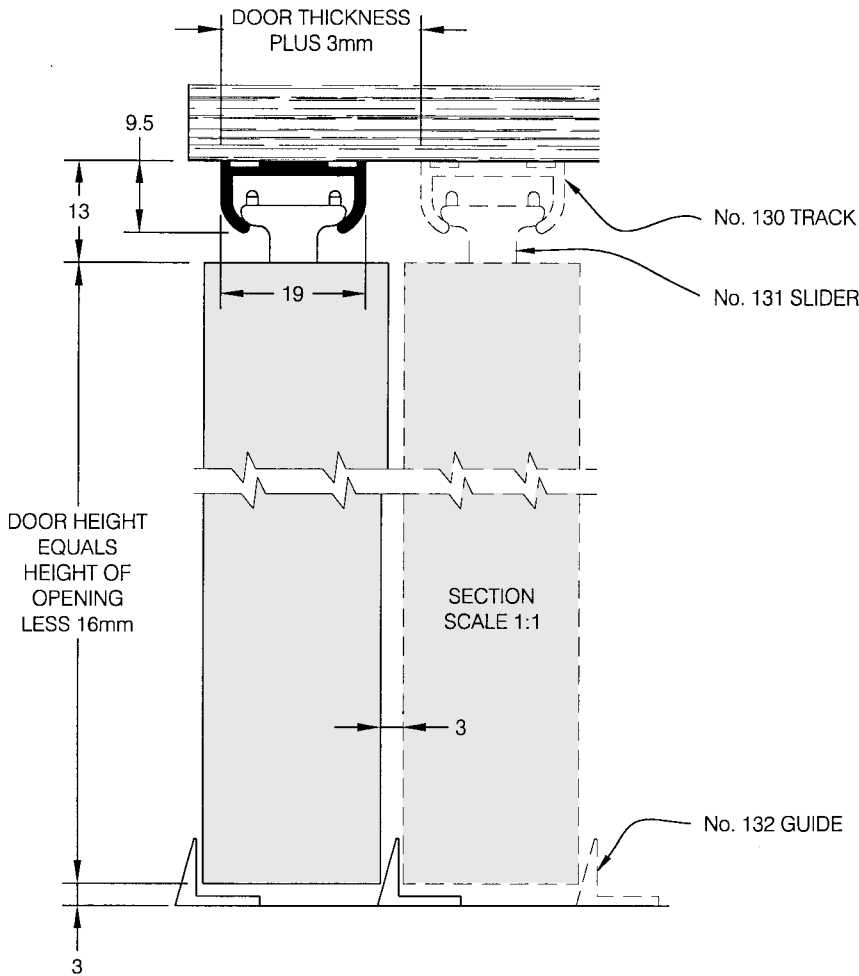

## FITTING INSTRUCTIONS

- 1 Screw sliders loosely to centre of top edge of door, as far apart as possible, avoiding end grain of stiles, using 32mm long screws.
- 2 Align sliders, using track as a straight edge. Tighten screws.
- 3 Cut track to opening width if necessary and screw to underside of lintel with 20mm long screws.
- 4 Hook door into track from outside. For double passing doors, hang inner door first.
- 5 With door hanging plumb, fit guides with two 13mm long screws. Alternatively groove underside of door as shown.

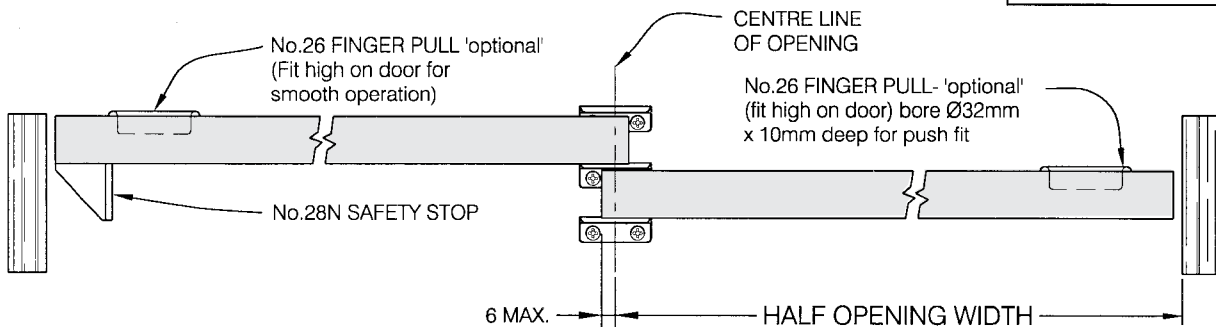
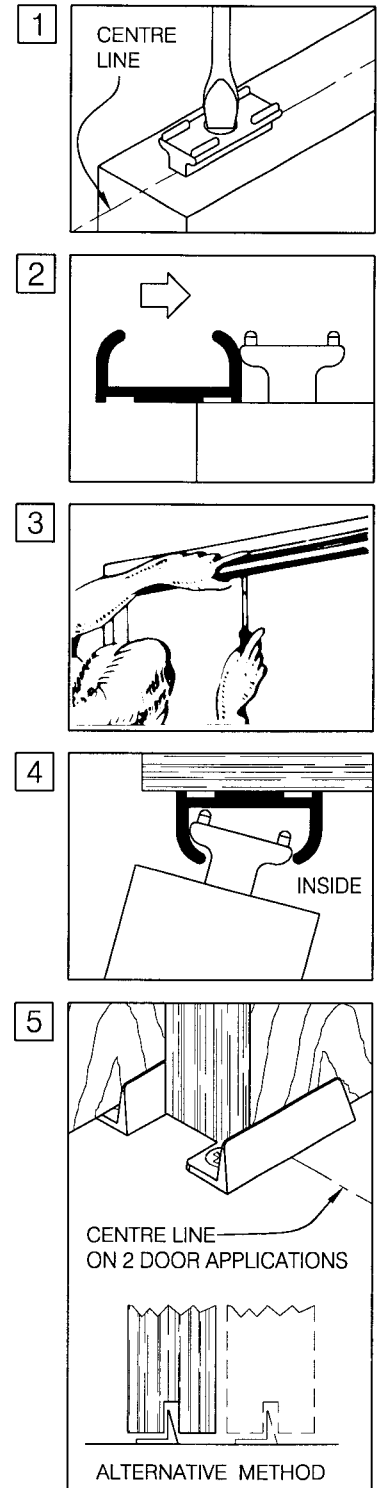

PLAN SHOWING 2 DOOR APPLICATION

B30B

## HENDERSON RMD

Door Hardware Division of  
**RMD PRESS CO. PTY LTD.**

ACN 004 313 937

© COPYRIGHT HENDERSON RMD

© HENDERSON IS A REGISTERED TRADEMARK OF PC HENDERSON LTD (UK)



SALES  
OFFICES  
IN ALL  
STATES