



**Cabiseal**  
CABISEAL.WT / CABISEAL.BK

**Product Details**

Cabiseal is a cover plate specifically designed to seal the access hole when connecting a dishwasher through cabinetry

Offering a high quality seamless finish, Cabiseal is also used in the finishing stage of the Cabiseal System, a reliable installation method ensuring consistency and increase to on-site efficiency

A simple two step process, the Cabiseal System involves implementation of a standardised CNC machined cut-out to production, for fit off with the Cabiseal cover plate after dishwasher installation

**Specifying the Cabiseal System:**

Cabiseal cover plate (BIM file or 3D render)  
Cabiseal cut out (DXF file download)

**Application clip, resource guide and specification downloads available at: [www.HarpIndustries.com.au](http://www.HarpIndustries.com.au)**

**Specification Sheet**

Recommended by



**Features**

- Original patented design
- 100% Australian Made to ISO9001 standards
- High quality chemical resistant ABS plastic
- Easy to install self locating design
- Retrofittable
- Packaged with required fixing screws
- Downloadable DXF file available for drilling template

**Manufacturer:** Harp Industries Pty Ltd

**Origin:** Australia

**Designer:** Damian Harpantidis

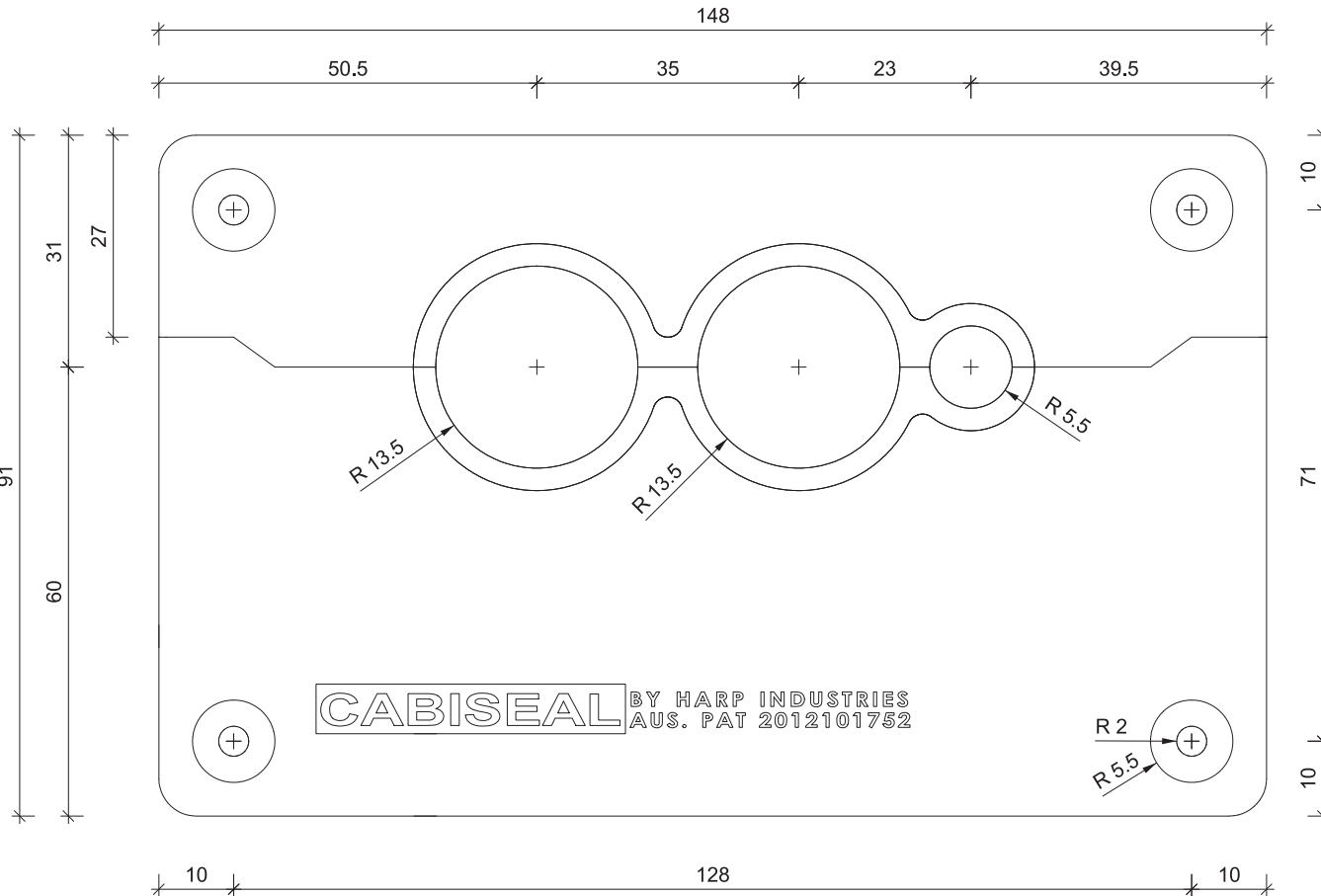

**PLAN**

Scale - 1:1 @ A4

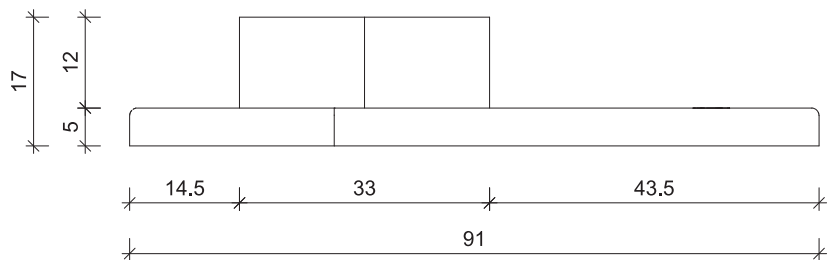

**SECTION**

Scale - 1:1 @ A4

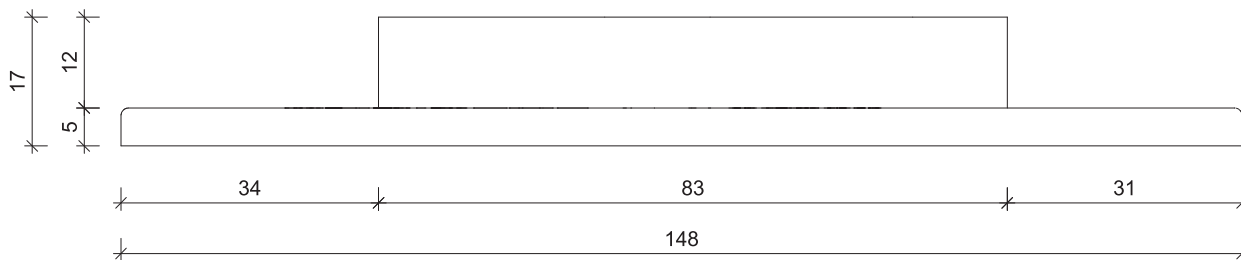

**ELEVATION**

Scale - 1:1 @ A4



All information provided in this specification sheet and associated Cabiseal files are accurate at the time of publication. Due to continuous development of the manufacturers products, the product, and therefore associated documentation is subject to change without notice. Please check with Harp Industries or recommended hardware distributor for the most current specifications.